

Insight  
ICA



Yearbook 2005

IMMIGRATION & CHECKPOINTS AUTHORITY



# Contents

Mission, Shared Vision & Core Values	12
Our Logo	13
Foreword by Our Commissioner	14
Get to Know Our Leaders	18
Our Organisational Structure	24
Our Checkpoints	26
Statistics for the Year	27
<b>Chapter 1</b>	
Get to Know Our Initiatives – Security	28
<b>Chapter 2</b>	
Get to Know Our Initiatives – Service	32
<b>Chapter 3</b>	
Get to Know Our Significant Cases	34
<b>Chapter 4</b>	
Get to Know Our Seminars & Visits	42
<b>Chapter 5</b>	
Get to Know Our Achievements & Awards	52
<b>Chapter 6</b>	
Get to Know Our People	56



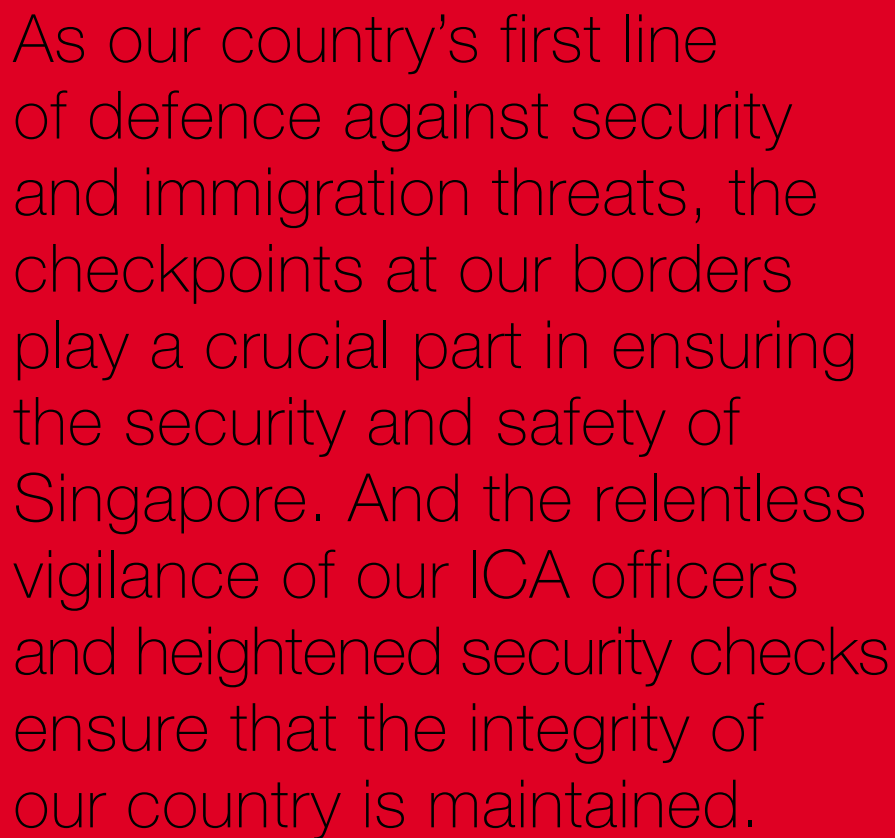

As our country's first line of defence against security and immigration threats, the checkpoints at our borders play a crucial part in ensuring the security and safety of Singapore. And the relentless vigilance of our ICA officers and heightened security checks ensure that the integrity of our country is maintained.

**WE UNCOVER ALL ILLEGITIMATE  
ACTIVITIES AT THE CHECKPOINTS.**

On 16 November 2005 at 1630hrs, a female Singaporean and her Vietnamese male friend were directed for checks at the baggage clearance section at Changi Airport Terminal 1. When asked if they had anything to declare, both of them said “no”.

Their bags however, told a different story. As they passed through the X-ray machine, an eagle-eyed ICA officer noticed some cigarette-like images in the bags. A more thorough physical search exposed some eight cartons and 72 packets of cigarettes creatively stashed in the bags: some were hidden in an electric kettle, some amongst clothing and medication, wrapped in cloth, some were even found in a wok!



16 November 2005, 1630hrs.





21 June 2005, 0245hrs.

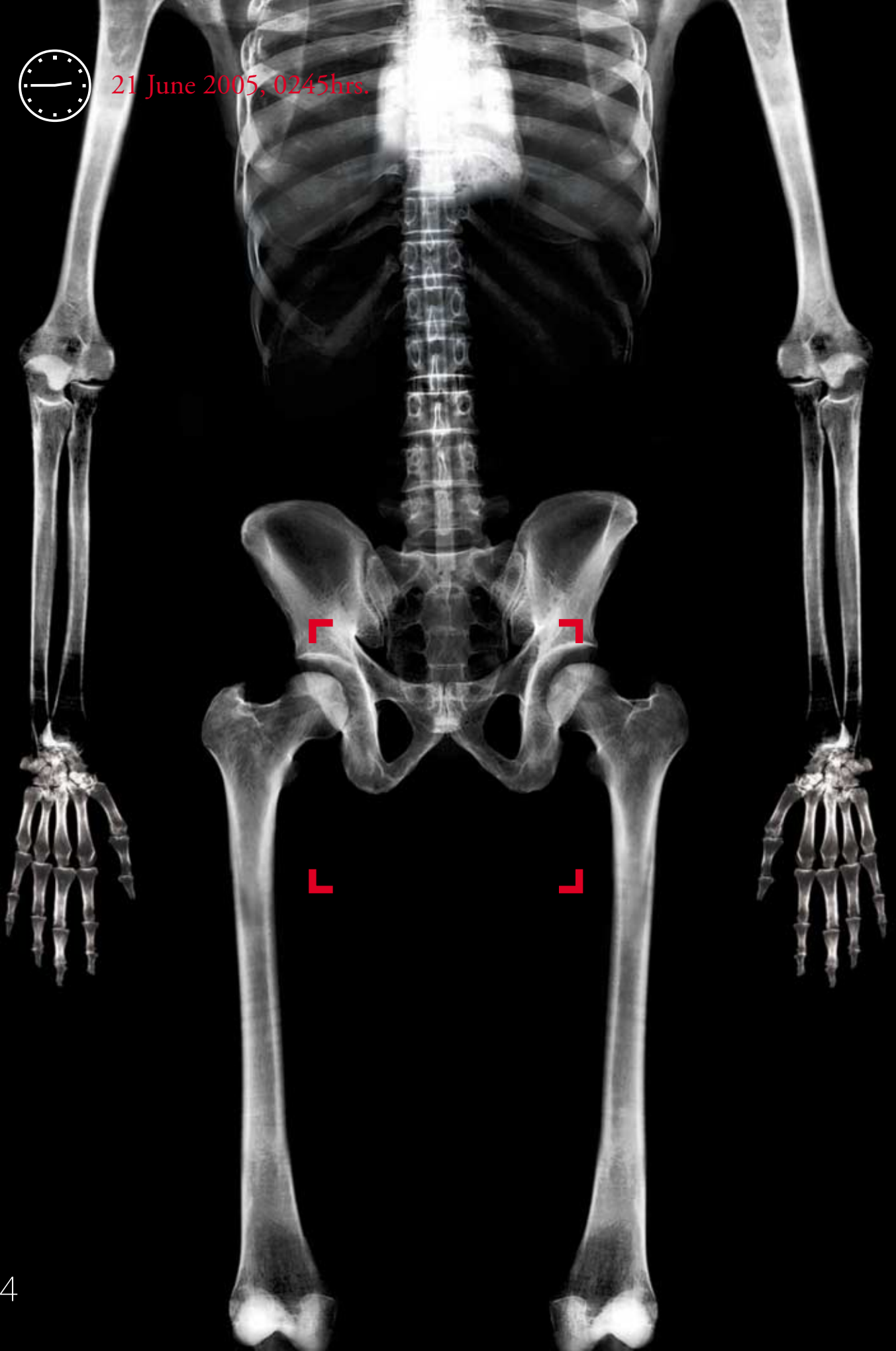

**WE EXPOSE ALL UNLAWFUL ACTS  
AND BEHAVIOURS AT THE CHECKPOINTS.**

On 21 June 2005 at 0245hrs, a taxi ferrying a single male passenger was stopped by ICA officers at the Woodlands Checkpoint. When asked to alight for checks, the passenger did so reluctantly. Our officers noticed an abnormal bulge at the front of his pants and proceeded to search him.

His game was up! The passenger surrendered when our officers found a pack of “Erimin 5” pills – a controlled drug in Singapore – in his pants pockets.

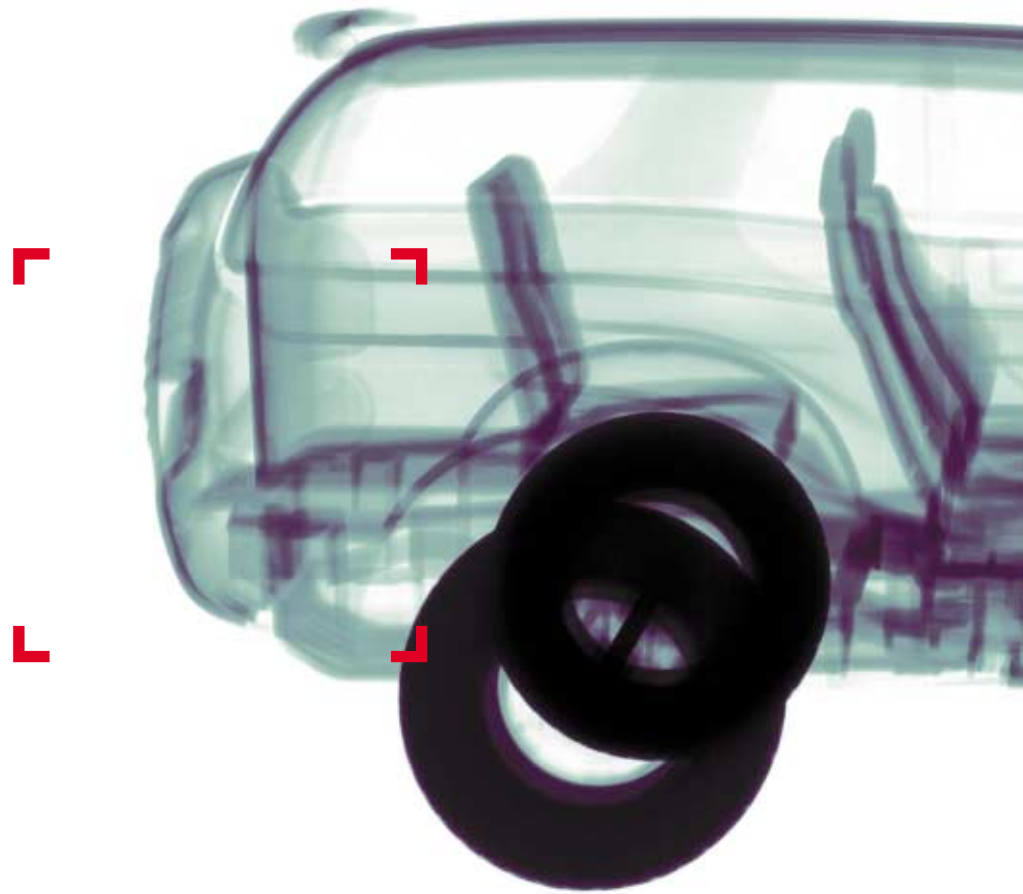

**WE HAVE THE DRIVE TO DETECT  
SMUGGLED GOODS AND PERSONS.**

On 11 November 2005, just past midnight, a pregnant Singaporean woman entered Singapore through the Woodlands Checkpoint in a Singapore-registered car. Unable to conceal her guilt, she behaved nervously and avoided eye contact with ICA officers.





11 November 2005, 0005hrs.

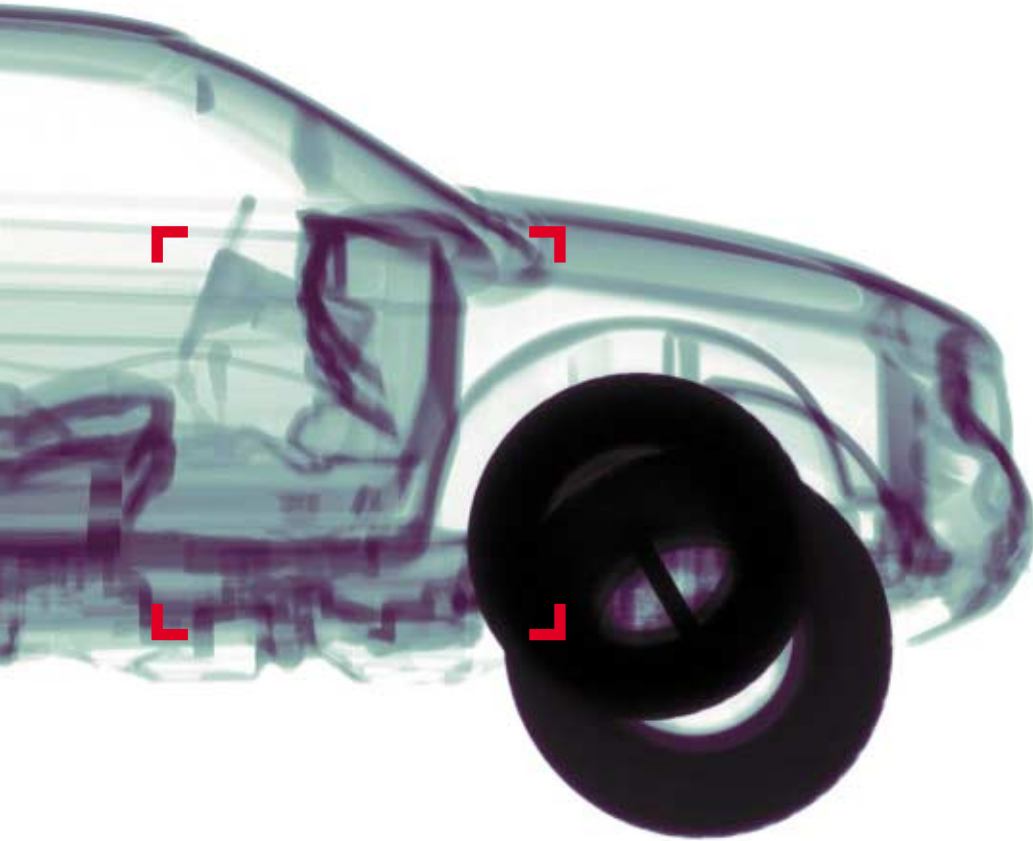

Quick on cue, officers performed a thorough check on the car and uncovered 1,270 packets of duty-unpaid cigarettes hidden in the speaker box and spare tyre compartment.



15 October 2005, 0605hrs.



**WE GET TO THE BOTTOM OF ALL  
SMUGGLING ATTEMPTS AT THE CHECKPOINTS.**

On 15 October 2005 at 0605hrs, a male Malaysian Work Permit holder riding a motorcycle was pulled over for a routine check at the Woodlands Checkpoint.

Nothing escapes the keen eyes of ICA officers – 20 packets of duty-unpaid tobacco were found stuffed in the right shoe of the Malaysian and in his left shoe, another 19 packets were found.

At ICA, we look beyond the surface. With state-of-the-art technology such as radiographic scanners to aid us in our duties, we have successfully detected and deterred the smuggling of undesirable persons, drugs, weapons, explosives and other contraband into and out of Singapore.

Now you know  
**what we do.**



Get to  
know us better.





### ICA Mission

We ensure that the movement of people, goods and conveyances through our checkpoints is legitimate and lawful. We administer and uphold our laws on immigration, citizenship and national registration fairly and effectively.



### Shared Vision

Inspiring Confidence in All

### Core Values

Integrity  
Commitment  
Accountability



### **DESCRIPTION OF ICA LOGO**

The State Crest conveys the message that Singapore's security is the main focus of ICA.

The Laurel Wreath signifies the Honour and Distinction of ICA, as part of the Home Team, in ensuring the safety and security of Singapore.

The Portcullis alludes to checkpoint control, symbolising effectual protection by managing the entry and exit of people, goods and conveyances.

Foreword by  
Our Commissioner



**“A weapon is only as powerful as the person wielding it. Our officers have embraced a security mindset and have taken a very serious view towards every smuggling attempt at the checkpoints.”**

**Mr Eric Tan, Commissioner  
Immigration & Checkpoints Authority**





CA continues to face many challenges, brought about by the heightened security landscape and an ever-changing operating environment. Singapore needs ICA to rise up to meet these challenges, and effectively secure her borders against terrorism, illegal immigration and other security threats.

Challenges can only make us stronger. Though 2005 was not an easy year for us, I am pleased to say that ICA has not only grown up, but has emerged more resilient than ever.

### **DELIVERING PERFORMANCE**

Our continued vigilance and stringent security checks at the checkpoints have foiled more than 18,000 attempts to smuggle unlawful goods and contraband into Singapore in 2005. This includes 300 attempts to smuggle security items such as handcuffs, air guns, stun guns and daggers.

Tough inland enforcement actions and security checks have effectively deterred immigration offenders from attempting to enter Singapore. About 10,100 immigration offenders were arrested in 2005, as compared to 11,800 in 2004.

A weapon is only as powerful as the person wielding it. Our officers have embraced a security mindset and have taken a very serious view towards every smuggling attempt at the checkpoints. When a smuggler tries to sneak in a few packets of cigarettes into Singapore, we see it for what it is – an attempt to test and breach our security.

## **JOURNEY TOWARDS ORGANISATIONAL EXCELLENCE**

ICA is not just about clearing immigration and cargo. As part of our ongoing efforts to achieve organisational excellence, we have attained both the Service Class certification and Singapore Innovation Class certification. These are major milestones in ICA's journey towards world-class quality service for our customers as well as making innovation a part of our daily efforts.

We will not rest on our laurels but will continue our journey to strive towards organisational excellence.

## **HARNESSING TECHNOLOGY**

Last year, we rolled out the Biometric Database for Immigration Clearance (BDIC) system at the checkpoints, the Visitor Services Centre and the Permanent Resident Services Centre. Foreigners with adverse records will have their particulars and fingerprints captured in the BDIC. This system allows for the easy identification of undesirable foreigners who try to re-enter the country with assumed particulars.

To stop determined vehicles from dashing in and out of the country without stopping for immigration and security clearance, we have installed crash barriers and cat claws at the land checkpoints as part of our anti-dash-through measures. We have also strengthened our arsenal of radiographic scanners with the Integrated Container Inspection System at the checkpoints to further thwart the smuggling of unlawful persons and goods.

## **LOOKING AHEAD**

Singapore will play host to a series of World Bank/International Monetary Fund meetings in September 2006. As always, ICA will maintain vigilance to stop any undesirable persons and goods entering Singapore through the checkpoints.

## **WORKING WITH OUR PARTNERS**

In order to achieve our mission and vision, ICA must continue to work with the community and our strategic partners. We would like to express our heartfelt appreciation for the support and cooperation that the Home Team, Government agencies, statutory boards and other organisations have given us in the past year. I am confident that there will be even more collaboration and cooperation between ICA and our strategic partners in the coming years.

As we progress into the new year, let us continue to work as one united team to *Inspire Confidence in All*.



**MR ERIC TAN**  
**COMMISSIONER**

**IMMIGRATION & CHECKPOINTS AUTHORITY**



Get to Know  
Our Leaders  
*(As of 1 January 2006)*



**MR ERIC TAN**  
**COMMISSIONER**

IMMIGRATION & CHECKPOINTS AUTHORITY



**MR KOH CHONG HWA**  
**DEPUTY COMMISSIONER**

OPERATIONS



**MR CLARENCE YEO**  
**DEPUTY COMMISSIONER**

POLICY & ADMINISTRATION



**MR JAMES LOW  
DIRECTOR**

**INTELLIGENCE**



**MR TUNG LENG KEI  
DIRECTOR**

**CORPORATE SERVICES**



**MRS LEE-HO SOW HENG  
DIRECTOR**

**POLICY**

The Intelligence Division provides timely and relevant intelligence to support ICA's operations. It is also responsible for taking enforcement action against offenders who violate the Immigration Act.

The Corporate Services Division provides corporate services support for ICA's operations. It is responsible for facilitating optimal resource management, and reviewing the logistical effectiveness in ICA.

The Policy Division oversees the formulation and review of policy and legislative matters and the promotion of naturalisation to support ICA's operations.



**MR BHOPINDER SINGH  
DIRECTOR**

**OPERATIONS**



**MRS PRAVINA JIT  
DIRECTOR**

**MANPOWER**



**MR ERIC CHUA  
DIRECTOR**

**PLANNING & TECHNOLOGY**

The Operations Division provides staff guidance to ICA's frontline operations at the Checkpoints and Enforcement Command, as well as develops operational policies and procedures.

The Manpower Division oversees the management and development of ICA's human resources, and administers the staffing needs of the organisation.

The Planning & Technology Division supports and develops ICA's strategic planning processes, as well as spearheads and manages technology projects to support ICA's operations.

## Get to Know Our Leaders



**MS JULIA SNG**  
**DIRECTOR**

**CORPORATE COMMUNICATIONS**



**MR TAN KOK GUAN**  
**SENIOR MANAGER**

**CITIZEN SERVICES CENTRE**



**MR JASWANT SINGH**  
**SENIOR MANAGER**

**VISITOR SERVICES CENTRE**

The Corporate Communications Division engages and interacts with ICA officers, ICA's customers and the community to promote awareness of ICA's programmes and policies so that there is better understanding and support for ICA's mission.

The Citizen Services Centre identifies individual citizens and lawful residents of Singapore, and issues them with official identification and/or proper travel documents.

The Visitor Services Centre regulates the stay of foreigners in Singapore and grants appropriate immigration privileges to those who qualify for long-term stay.



**MR KNG ENG KIAT**  
**SENIOR MANAGER**

**PERMANENT RESIDENT SERVICES CENTRE**



**MR LEE CHIAN TAK**  
**COMMANDER**

**WOODLANDS COMMAND**



**MR TAN HANG TJONG**  
**COMMANDER**

**AIR CARGO COMMAND**

The Permanent Resident Services Centre implements policies for the retention and absorption of desired foreigners for our national interests, and regulates the entry of foreigners with family ties into Singapore.

The Woodlands Command oversees the movement of people, goods and conveyances through the checkpoint by land. It is also responsible for the operations of the train checkpoint.

The Air Cargo Command oversees the expeditious and effective clearance of air-borne cargo through the Changi Airfreight Centre Checkpoint and the Parcel Post Centre. It is also responsible for passenger and baggage clearance at Seletar Airport.



**MR ONG CHOO KEE  
COMMANDER**

**ENFORCEMENT COMMAND**

**MR TAN POH KEE  
COMMANDER**

**AIRPORT COMMAND**

The Enforcement Command is primarily responsible for the effective control of the immigration situation in Singapore through the investigation, prosecution and repatriation of immigration offenders.

The Airport Command oversees the movement of goods and people through the Singapore Changi Airport Terminals.



**MR NAM LIANG CHIA  
COMMANDER**

**COASTAL COMMAND**

**MR WONG KONG WA  
COMMANDER**

**TUAS COMMAND**

The Coastal Command oversees the movement of people and goods through the sea checkpoints and other designated sea entry/exit points.

The Tuas Command oversees the movement of people, goods and conveyances through the checkpoint by land. It is also responsible for clearing vehicles that transport hazardous materials and live poultry/poultry products from Malaysia.

# Get to Know Our Leaders



**MR LIM WEI MENG**  
**COMMANDER**

**PORTS COMMAND**



**MR TAN HOCK GUAN**  
**1 DEPUTY DIRECTOR**

**OPERATIONS**



**MR MOHD FARHAD BIN**  
**MOHD SHARIFF**  
**2 DEPUTY DIRECTOR**

**INTELLIGENCE**

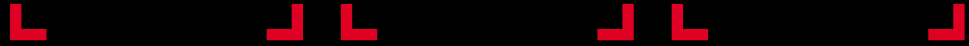

The Ports Command oversees the expeditious and effective clearance of containerised and conventional sea-borne cargo.



**MRS EVELYN WU**  
**DEPUTY DIRECTOR**

**TRAINING**



**MR DAVID TAN**  
**DEPUTY DIRECTOR**

**POLICY**



**MS LOH SOCK TUAN**  
**DEPUTY DIRECTOR**

**FINANCE**

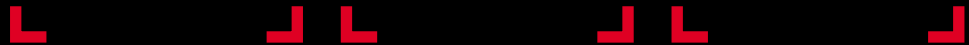





**MR NG LOH SIAH**  
**2 DEPUTY DIRECTOR**

OPERATIONS



**MRS SHARON WEE**  
**DEPUTY DIRECTOR**

PLANNING



**MS TAN SOR HOON**  
**DEPUTY DIRECTOR**

TECHNOLOGY



**MR BOON SIAN MENG**  
**1 DEPUTY DIRECTOR**

INTELLIGENCE

# Our Organisational Structure

(As of 1 January 2006)

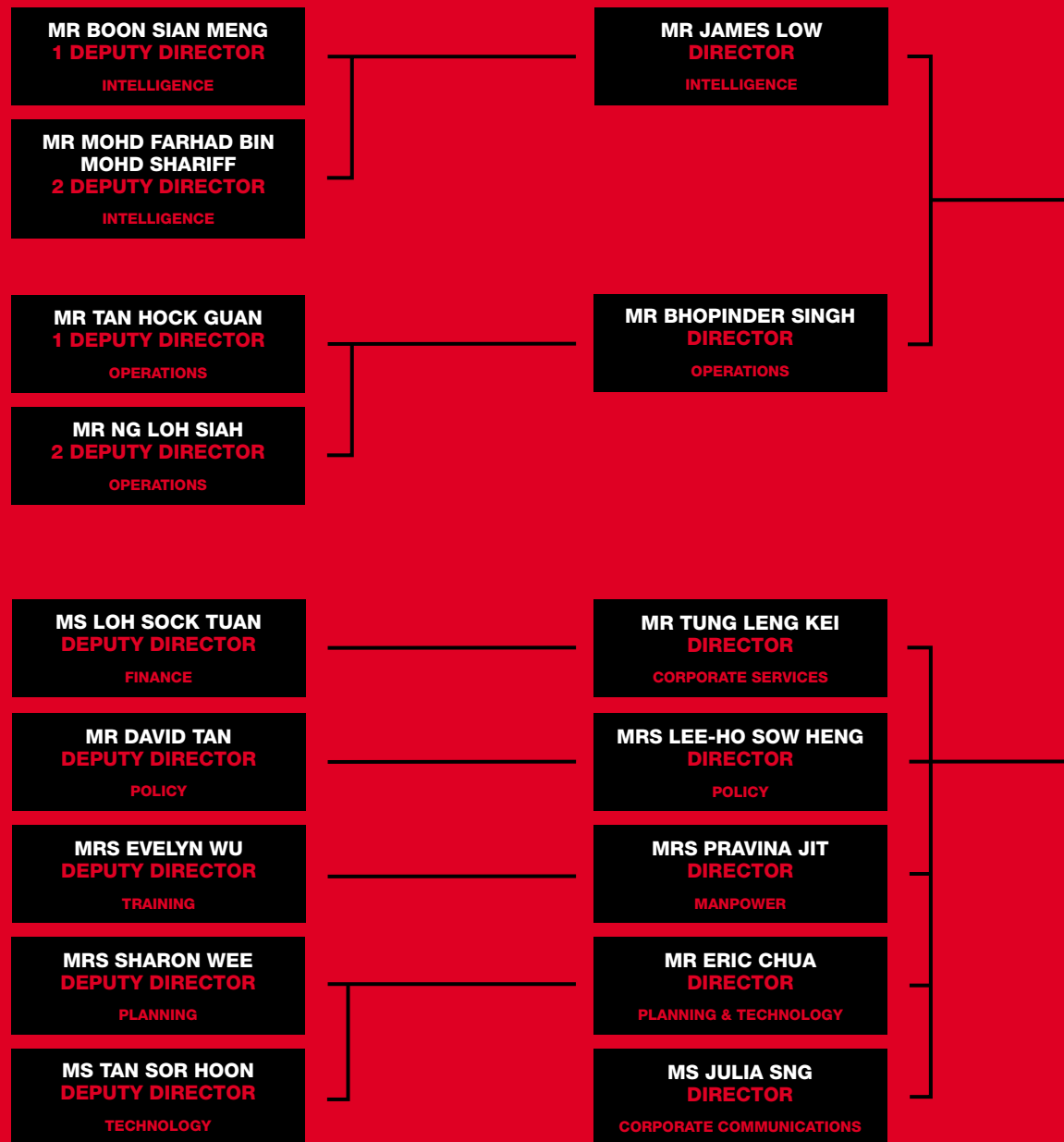

**MR ERIC TAN**  
**COMMISSIONER**  
IMMIGRATION &  
CHECKPOINTS AUTHORITY

**MR KOH CHONG HWA**  
**DEPUTY**  
**COMMISSIONER**  
OPERATIONS

**MR CLARENCE YEO**  
**DEPUTY**  
**COMMISSIONER**  
POLICY & ADMINISTRATION

**INTERNAL AUDIT**

**MR LEE CHIAN TAK**  
**COMMANDER**  
WOODLANDS

**MR WONG KONG WA**  
**COMMANDER**  
TUAS

**MR TAN POH KEE**  
**COMMANDER**  
AIRPORT

**MR TAN HANG TJONG**  
**COMMANDER**  
AIR GARGO

**MR NAM LIANG CHIA**  
**COMMANDER**  
COASTAL

**MR LIM WEI MENG**  
**COMMANDER**  
PORTS

**MR ONG CHOO KEE**  
**COMMANDER**  
ENFORCEMENT

**MR TAN KOK GUAN**  
**SENIOR MANAGER**  
CITIZEN SERVICES CENTRE

**MR JASWANT SINGH**  
**SENIOR MANAGER**  
VISITOR SERVICES CENTRE

**MR KNG ENG KIAT**  
**SENIOR MANAGER**  
PERMANENT RESIDENT  
SERVICES CENTRE

## Our Checkpoints

Our officers' continued vigilance at the Land, Air and Sea Checkpoints acts as a line of defence against the entry of undesirable persons and cargo to ensure the continued security of our homeland.

Beyond the Checkpoints and Services Centres, we also conduct inland enforcement against immigration offenders and ensure their subsequent prosecution and repatriation.

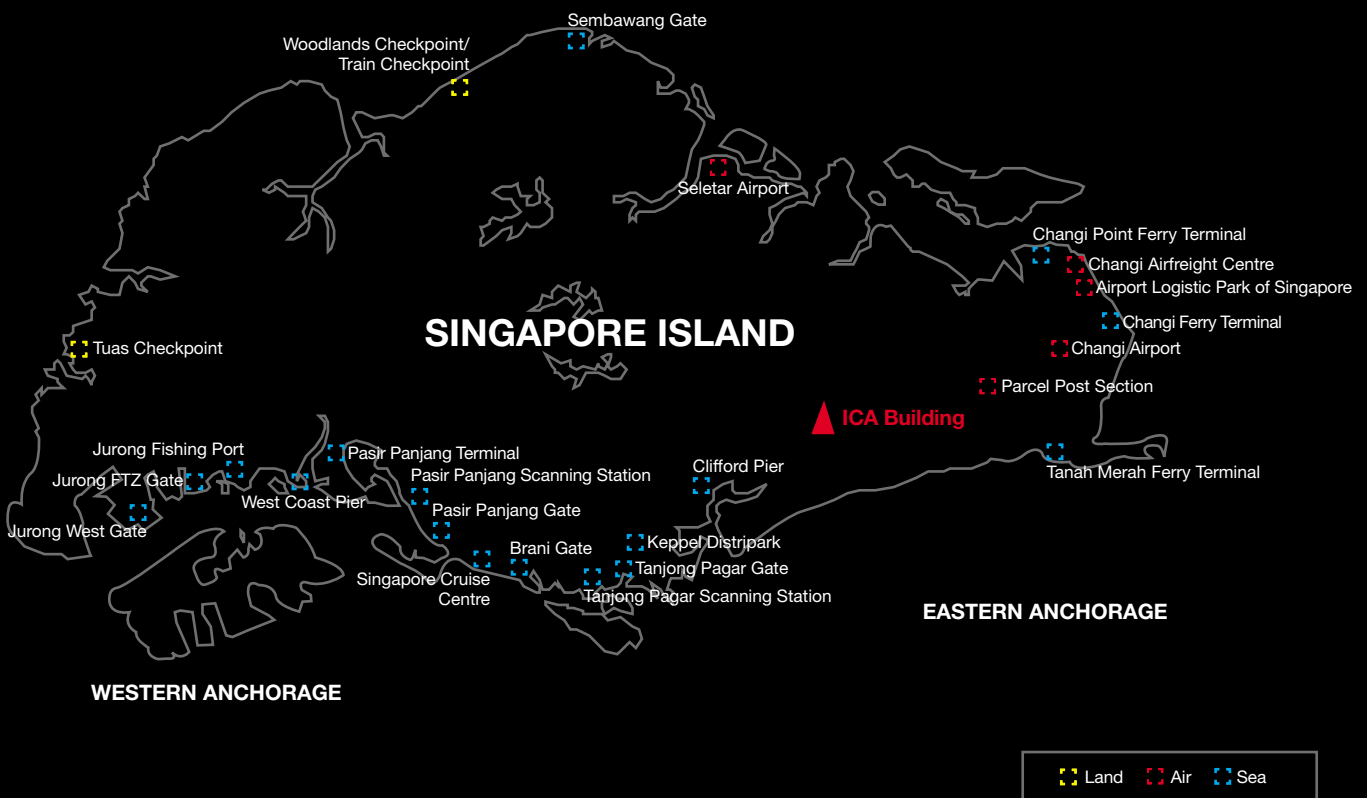

# Statistics for the Year

## FACTS & FIGURES

### Checkpoint Operations

	2005	2004	2003
Number of passengers cleared at the checkpoints			
Arriving	66,313,400	65,460,100	59,136,400
Departing	66,730,100	65,682,800	59,348,200
Number of inward containers	782,500	926,700	1,340,500
Number of inward consignments cleared at the checkpoints	2,990,080	3,934,500	3,952,900
Number of parcels cleared at the Parcel Post Section	1,148,900	1,175,900	1,240,800

### Services Centres Operations

Number of applications for citizenship approved	12,900	8,500	6,400
Number of identity cards issued	92,000	79,100	79,500
Number of Singapore passports and certificates of identity issued	272,100	242,100	221,100
Number of passes and permits (excluding re-entry permits) granted to foreigners	476,600	388,500	286,800
Number of live-births registered	37,590	37,170	37,490
Number of deaths registered	16,220	15,860	16,000

### Enforcement Operations

Number of illegal immigrants	4580	5400	5510
Number of overstayers	5500	6390	6340
Number of harbourers	173	245	333
Number of employers of immigration offenders arrested	167	220	270
Number of contraband cases detected	17,000	18,255	8,420
Number of vehicles used in the smuggling of illegal immigrants seized	3	20	17



Chapter

# 1

Get to Know  
Our Initiatives  
**SECURITY**

SECURITY

**DASH AND CRASH!**

CA has been paying close attention to Singapore's border security by tightening and enhancing control measures.

Anticipating the possible scenario that perpetrators may try to use vehicles to dash through the checkpoint, ICA has introduced a series of anti-dash-through measures at the land checkpoints. If someone tries to evade immigration and security clearance by dashing through the checkpoint, the alarm system will be activated. All lanes will be temporarily closed to prevent the vehicle from passing through. The drop-arm barriers and traffic lights placed strategically further down the lanes serve as further deterrents.

If these barriers do not stop the vehicle, the driver is in for a rude (and painful!) shock. Crash barriers capable of stopping a ten-tonne truck going at 100km/h will be activated in less than three seconds. In addition, heavy-duty spike barriers will cause severe damage to the vehicle by ripping off the tyres and destroying its undercarriage. Those in the car may also suffer serious injuries.

A demonstration of the capabilities of the crash and spike barriers was held at the old Woodlands Checkpoint on 16 August 2005. The crash barriers stopped a speeding ten-tonne truck in its tracks while the spike barriers shredded the truck's tyres, undercarriage and fuel tank.

The impressive capabilities of these barriers ensure that no vehicle, even the most foolhardy and determined, will be able to bypass our checkpoints.





### **THUMBS UP FOR BIOMETRIC DATABASE**

**Y**ou can change your name or the particulars in your passport, but you cannot alter your biometric features. Foreigners who have been barred from entering Singapore were dismayed when the Biometric Database for Immigration Clearance (BDIC) was implemented at the checkpoints on 1 June 2005. Criminals or those who had previously committed immigration offences have their particulars and fingerprints captured in the BDIC. In the second half of 2005, some 800 of these foreigners tried to enter Singapore using passports with assumed names and particulars and were detected when the BDIC exposed their true identities.

Even those who tried to outsmart the BDIC system's capabilities by slashing their fingers or applying superglue to their fingers, found their efforts in vain as the BDIC was able to uncover their real identities.



**With 3,600 officers on board, ICA is a force to be reckoned with when it comes to preventing the infiltration and harbouring of unlawful goods and persons into Singapore.**

### **SINGAPORE BIOMETRIC PASSPORT – A LIVE TEST**

**A**s part of our overall security efforts, Singapore will be introducing the new biometric passports by August 2006. These biometric passports will restrict the space for terrorist movements by tightening passport controls and border surveillance, and will also allow us to stay ahead of syndicates using forged travel documents.

We are currently working with the United States (US), Australia and New Zealand to test the biometric passports (issued by the respective countries) in a live environment. The test will give Singapore the opportunity to assess the operational impact of reading other countries' biometric passports using our readers and vice versa. About 2,000 Singaporean SIA crew were enrolled in the trial to use their trial biometric passports at overseas airports.

Those who do not hold biometric passports need not fret – they can still enjoy visa-waiver entry into the US for trips not exceeding 90 days, as long as they have a valid machine-readable passport. All Singapore passports issued in Singapore from 2 January 1991 are machine-readable.

### **ICA UNLIMITED**

**W**ith 3,600 officers on board, ICA is a force to be reckoned with when it comes to preventing the infiltration and harbouring of unlawful goods and persons into Singapore. The level of effectiveness is multiplied when we have thousands of Singapore residents on our side!

ICA is achieving this through our community involvement initiatives and public education programmes. With effect from January 2005, housing agents will act as one of the lines of defence to verify a foreigner's immigration status before recommending him or her to homeowners as a potential tenant. The Community Involvement Branch had conducted briefing sessions for 780 housing agents to help familiarise them with this new requirement.

We have also produced an Agent Handbook in July 2005 to raise the awareness of the potential social and security problems resulting from immigration offenders. The booklet is being distributed to all households in Singapore, covering information such as the different types of foreign passes, immigration checks, and the available helplines where members of the public can seek assistance on related immigration issues. Available in four languages, the booklet aims to harness an effective partnership between ICA and the community to address these issues.

Chapter

# 2

Get to Know  
Our Initiatives

**SERVICE**



## Get to Know Our Initiatives

### SERVICE



### AS EASY AS **ABTC** (APEC BUSINESS TRAVEL CARD SCHEME)

**O** n 1 October 2005, Singapore implemented the Asia-Pacific Economic Cooperation (APEC) Business Travel Card (ABTC) Scheme, for which ICA is the issuing authority.

The ABTC scheme was implemented to facilitate business travel between APEC countries. Business travellers who hold the ABTC can enjoy streamlined clearance at major airports and entry points of participating economies. Designated lanes have been set up at all checkpoints to provide quick and efficient immigration clearance for foreign cardholders who have been pre-cleared by Singapore. Cardholders can also travel to the participating economies for business purposes for a period up to 60 or 90 days, without the need for separate visa applications.

Bona fide business persons, members of professional bodies such as doctors, lawyers, artists and public officers who need to travel in their official capacity are eligible to apply for the card.

#### APEC countries participating in the ABTC scheme

Australia, Brunei Darussalam, Chile, China, Chinese Taipei, Hong Kong, Indonesia, Japan, Republic of Korea, Malaysia, New Zealand, Papua New Guinea, Peru, the Philippines, Singapore, Thailand and Vietnam.

**Note:** While Papua New Guinea and Vietnam had announced their participation in the scheme, they have yet to commence processing local or foreign card applicants. They are expected to commence operations in the near future, but no fixed dates have been set.

### SAVE! TIME

**I** CA constantly leverages on IT to improve the quality of our services and streamline our work processes. The Submission of Application for Visa Electronically (SAVE) is one such initiative.

SAVE was launched in October 2004 at the ICA HQ's Visitor Services Centre, as well as at Singapore Missions in Bangladesh, China, Hong Kong, India, Iran, Pakistan and Saudi Arabia. SAVE makes the visa application a breeze for end users. Instead of making two trips to ICA to submit the documents and collect the visa, applicants can perform both steps at the same time, thanks to SAVE. It shortens the waiting time and also offers the convenience of making payments via credit card.

By early 2006, the use of this system will be expanded to Singapore Missions in Egypt and United Arab Emirates (UAE), and in Russia and the South East Asian countries in the later part of 2006.

Chapter

# 3

Get to Know  
Our Significant Cases





## ICA SINKS ATTEMPT TO SMUGGLE 2,600 CARTONS OF CIGARETTES ON A BARGE



22 March 2005, 0930hrs,  
Western Petroleum Anchorage,  
Coastal Command

### INFORMATION RECEIVED



CA officers intercepted a tugboat berthing at Pasir Panjang. They swiftly boarded the tugboat that was towing a barge with containers and conducted a search.

### TELLTALE SIGNS OF ILLEGAL ACTIVITY

One of the ballast tanks on the right side of the barge appeared to have been tampered with and a heavy coil of rope had been placed on the opening to deter ICA officers from opening the cover. Another telltale sign was the suspicious nature of the crew members, who appeared nervous, avoided eye contact when questioned and were uncooperative.

### UNYIELDING PERSEVERANCE AND PROFESSIONALISM

Determined to uncover the truth, our officers removed the cover and went into the ballast tank to find about 2,600 cartons of duty-unpaid cigarettes. Subsequent checks revealed that all the containers on the barge were actually empty.



**“The enclosed ballast tank was hot and humid and possibly even contained poisonous gas. By hiding the contraband cigarettes in such a hazardous place and placing empty containers on the barge, the smugglers obviously intended to deceive and deter officers from searching the area. Whatever the modus operandi, ICA will continue to leverage on our strong intelligence resources and capabilities and vigilant officers to nab those who are involved in the activity.”**

**Supt Nam Liang Chia, Commander of Coastal Command**

## BRIEF INFORMATION ABOUT VACIS

Radiographic scanners such as VACIS (Vehicle and Cargo Inspection System) help ICA officers do our work well. With these scanners, we are able to “see” the contents of a container swiftly without having to conduct a physical inspection of the container. This allows for the effective and efficient scanning of containers.

## CHINESE SMUGGLERS FAILED TO SMOKE THEIR WAY THROUGH



5 October 2005, 1900hrs,  
Tanjong Pagar Scanning Station,  
Ports Command

### RIGHT ON TARGET

**A** container was targeted for radiographic scanning at Tanjong Pagar Scanning Station. The officer's suspicion was aroused when he saw some discrepancies in the scanned image of the consignment so he proceeded to inspect the container.

### WHAT A LOAD!

Secondary inspection uncovered 200 kilogrammes of “Ang Hoon” packed in five big cartons, 90 cartons of duty-unpaid cigarettes, ten cartons of Chinese medicine including “Chinese Viagra” and 1,450 pieces of uncensored discs. The customs duties and Goods & Services Tax evaded for the cigarettes and tobacco products amounted to almost \$76,000 and \$4,000 respectively. Under Section 130(1)(a) of the Customs Act, it is an offence to import dutiable goods without paying customs duties.

The offender pleaded guilty to the charges and was sentenced to a total of 49.5 months of imprisonment.



# Get to Know Our Significant Cases

## SILENT HISS



27 July 2005, 2015hrs,  
Arrival Cargo Clearance Centre,  
Woodlands Command



ICS Lim Tiong Khoon & SICS Mohd Saem B Amat stopped a lorry, which was supposed to be carrying a consignment of speaker parts, for a thorough check and scan. Officers observed some discrepancies in the scanned image and proceeded to remove the cartons in the lorry for a detailed check on the cargo.

### WHAT LIES BENEATH

The check unveiled about ten packets of dry snake skin, weighing about 563 kilogrammes, among the consignment. The driver was immediately arrested and the dried python skins seized.

The Reticulated Pythons are an endangered species protected under the Convention on International Trade in Endangered Species of Wild Fauna and Flora (CITES), to which Singapore is a Party. Under the Singapore's Endangered Species (Import and Export) Act (ESA), it is an offence for any person to import and export CITES-protected species without a permit from the Agri-Veterinary Authority (AVA).



## MORE THAN MEETS THE ICE



29 September 2005, 0605hrs,  
Arrival Cargo Checking Bay,  
Tuas Command

### TRUTH OR DARE?

When a Malaysia-registered lorry driven by a male Malaysian Indian arrived at the A6 cargo checking platform for secondary checks, the vigilant officer on duty, HICS2 Pantithai d/o Karupiah, noticed that there was something suspicious about the driver and his consignment of 600 bags of ice-cubes, weighing about 15 kilogrammes each.

### METICULOUS EFFORT PAID OFF

As the vehicle was being directed for a radiographic scan, HICS2 Pantithai scrutinised the passport and discovered that the driver was underaged to drive a lorry of that size. Further questioning revealed that the driver did not even have a valid driver's license.

### ICY-COLD CONTRABAND

A detailed check on the bags of ice in the vehicle uncovered 3,497 cartons of duty-unpaid cigarettes, with an estimated street value of about \$315,000.





## Get to Know Our Significant Cases

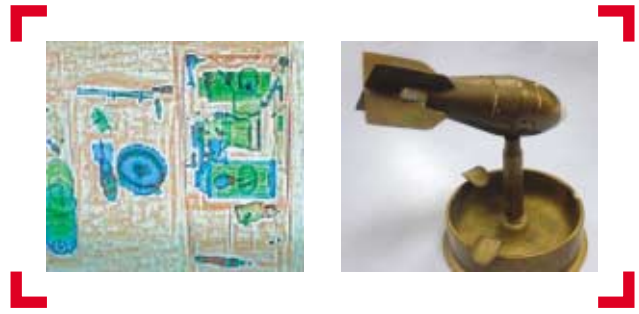

### **ATTEMPT TO SMUGGLE AMMUNITION SHOT DOWN**



17 July 2005, 0500hrs,  
Air-Mail Transit Centre (ATC),  
Air Cargo Command

#### **VIGILANCE + TEAM WORK**

**S** ICS Azhar B Mohd Basar, HICS Immrah B Zainal & HICS Ho Lian Yee were deployed to perform X-ray screening of incoming parcels at ATC. In the early hours that morning, SICS Azhar came across an X-ray image that looked like a mortar round and alerted the other two officers.

After reviewing the image, all operations were called to a halt and the police were notified.

#### **SPRINGING INTO ACTION**

The parcel was inspected for traces of explosives using an explosives detector. After police had assessed that there was no serious security threat, the parcel was opened.

#### **TAKING A PEEK...**

The parcel contained an empty tank shell base, a 7.62 mm GPMG empty cartridge, a M16 bullet head, a miniature empty mortar round, an envelope containing US\$24, six packages of assorted spray gun cleaning kits with accessories, and a wooden model submarine.

The six packages of cleaning kits and the wooden model submarine were returned to the addressee while the other items in the parcel were seized.

Under the Arms & Explosives Act (Cap 13), it is an offence to import unlawfully or without a licence, any guns, arms, explosives or poisonous or noxious gas or noxious substance.



## **OPS DENY SANCTUARY NAB OVER 100 IMMIGRATION OFFENDERS IN A SINGLE SWOOP**

**An account by AS Patrick Ong, Analyst, Research & Analysis Branch**

In late October 2005, ICA received information that a large community of immigration offenders was occupying a rundown two-storey office building at Sungei Kadut Avenue. Upon verification that the information was accurate, our officers started planning for an operation, coded Ops Deny Sanctuary. The operation was conducted in the wee hours of 22 November 2005 and involved 73 ICA officers. One of them who had answered the clarion call to take part in this major operation was AS Patrick Ong. Read on for his first-hand account of the operation.

### **PRE-OPERATION PREPARATION**

We gathered at ICA HQ at midnight. Preparation started with a briefing on the type of immigration offenders we were expecting and the logistical arrangements. I was particularly impressed by the comprehensive reconnaissance work conducted. We were then divided into groups and my team was given the responsibility of guarding the rear of the building to stop fleeing immigration offenders from jumping from the building.

### **MOVING IN**

It was eerily silent and pitch dark at the site. All the respective teams got into their designated positions. It was only when the strike force entered the building that shouts and banging noises were heard. Where I was stationed, I could see some of the occupants appearing at the window intending to escape. Our quick reflexes and the watertight cordoning rendered their attempts futile.

### **ALL OVER IN HALF AN HOUR**

The entire operation started and concluded within half an hour. Lines of immigration offenders in varying stages of undress were led out by ICA officers. An inspection of their quarters revealed cramped and filthy living conditions.

For the 102 immigration offenders arrested, their unwelcome stay in Singapore had come to an abrupt end. For the officers and I who had participated in the operation, the experience has led to a renewed sense of mission that ICA is a force to be reckoned with.

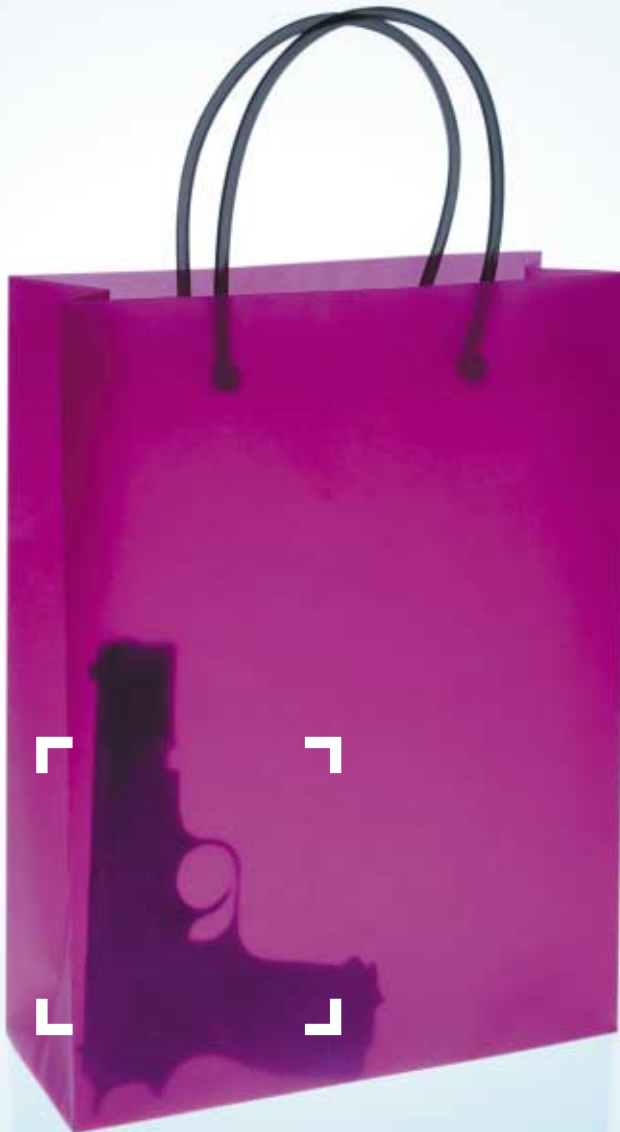

## AIR GUNS SEIZED AT CHANGI AIRPORT



11 December 2005, 1550hrs,  
Arrival West, Terminal 1,  
Airport Command

### VIGILANT OFFICERS

During a routine screening of a flight from Bangkok, SICS Kwek Sock Geak noticed pill-like images in one of the bags of a Singaporean couple. When asked if they had anything to declare, the couple said no.

### FURTHER CHECKS CONDUCTED

Another ICA officer, HICS Kamsinah Abdullah, proceeded to check their bags and found a package containing some plastic pellets in one of their bags. Two aluminum-wrapped packages were also found in the bag.

### CAUGHT RED-HANDED

Upon unwrapping the packages, ICA officers found two sport air guns. When queried, the subjects admitted ownership to the guns and plastic pellets. However, both could not explain the intent for attempting to bring the sport air guns into Singapore. The items were seized by Airport Police.

Under the Arms & Explosives Act (Cap 13), it is an offence to import unlawfully or without a licence, any guns, arms, explosives or poisonous or noxious gas or noxious substance. Anyone who contravenes this section shall be guilty of an offence and shall be liable on conviction to a fine not exceeding \$10,000 and to imprisonment for a term not exceeding three years.



Chapter

# 4

Get to Know  
Our Seminars  
& Visits

## COUNTER TERRORISM & SECURITY WORKSHOPS/SEMINARS 2005

In line with the Ministry of Home Affairs' ongoing efforts to maintain vigilance against terrorism, ICA has initiated a series of counter terrorism and security seminars aimed at raising the level of awareness among our officers.

The seminars were conducted in phases. The middle and senior management attended a course conducted by Dr Rohan Gunaratna, the Head of Terrorism Research at the Institute of Defence and Strategic Studies. Speakers from the Internal Security Department were also invited to brief our senior officers on security and terrorism-related topics.

ICA had identified and trained a core group of officers to conduct in-house seminars. Between July and November 2005, a series of one-day Counter Terrorism & Security (CTS) Seminars was conducted by these trainers for our officers. The seminars gave our officers a good overview of terrorism issues in Southeast Asia and Singapore, including suicide terrorism and the psychology of suicide terrorists.

**“I hope that the workshops will help officers internalise the counter terrorism measures and enhance their security awareness. Security or counter terrorism is not something that can be instilled in a person after one or two days of briefing, but rather, developed through a continuous process of questioning and rationalising, even the fundamentals which we have always taken for granted.”**

**AS Tan Susie, Analyst, Research & Analysis Branch**

**“This awareness course gave officers a general understanding of terrorism and its impact, which is critical for frontline officers. As a trainer, it was an opportunity to brush up my presentation skills as we needed to face as many as 200 officers in each session. Terrorism is very real and we, at the frontline play an important role in ensuring the safety of our homeland and fellow countrymen and women.”**

**DS Tan Yih Wann, Assistant Commander (Passenger), Woodlands Command**



## **TRAINING COURSE IN CAMBODIA**

### **An account by M. Elangovan, Airport Command**

**H** ICS2 M. Elangovan, Ops and Intel Officer in Airport Command, and AS Tan Wei Ling, Investigation Branch Officer attended a two-week training course in Cambodia. The training was designed to develop and enhance practical skills in investigative interviewing and profiling, as well as to promote greater cooperation and information sharing across borders.

#### **MY FIRST IMPRESSION**

Before going to Cambodia, I read all the materials I could find on the country. I was so excited. Friends have told me so much about the 'unbelievable efficiency', the 'beauty of Cambodia', and above all, the 'friendliness' of the Cambodians. I witnessed all of these during the training course in Cambodia. We stayed at the Hotel Cambodiana, located on the banks of the Mekong River, which was also the venue for the two-week training.

#### **COURSE OUTLINE**

One interesting module that was covered during the course was Investigative Interviewing and Profiling. This module included topics such as verbal and non-verbal communication, guides to detecting deception, establishing identities, taking statements and developing profiles on people and organisations, in the context of migration management and border control. Special emphasis was placed on preventing and combating terrorism and other forms of transnational crime. The training methodology consisted of short presentations followed by discussions and supervised practice sessions.

A one-day module on the individual psychological and sociological characteristics of terrorists from different generations as well as their groups gave us the opportunity to study how the terrorist profile may have changed in recent decades, and whether they share any common sociological attributes.

I was given the opportunity to make a presentation on "Investigative Profiling" during the course, which aimed to provide insights to developing a profile to help security personnel identify potential terrorists. My colleague AS Tan Wei Ling gave a presentation on "Facial Recognition",



## Get to Know Our Seminars & Visits

which aimed to help participants identify terrorists who use forged or look-alike documents to cross borders.

The trip was very fruitful. When I returned to Singapore, I gained not only in terms of newfound knowledge, but also strong friendships with my fellow course participants.

### **BALI PROCESS IMMIGRATION INTELLIGENCE WORKSHOP ON OPERATIONALISING IMMIGRATION INTELLIGENCE**

**S**ingapore hosted a workshop on “Operationalising Immigration Intelligence” from 17 to 19 January 2006. The workshop, organised under the auspices of the Bali Ministerial Process on People Smuggling, Trafficking in Persons and Related Transnational Crime, was co-chaired by Australia and Singapore.

The workshop provided a forum for interaction and sharing of experiences on the collection, analysis and use of intelligence, allowing representatives from the 40 Bali Member States to understand how immigration intelligence can be used in their operations.

During the three-day workshop, delegates engaged in various discussions on pre-arrival processing, risk management at air and land checkpoints and post-arrival processing to develop work processes and measures to address the illegal immigration problems with the available intelligence. Incorporated into the programme was a half-day site visit to Woodlands Checkpoint, which aimed to provide an understanding of the operations of a busy land checkpoint.



## **THE HOME TEAM COMMAND AND STAFF COURSE 2005**

Three of our ICA colleagues, DS Chia Hoi Mun, DS Damien Gan and DS Lee Teck Seng attended the 3rd Home Team Command & Staff Course (HT C&S) 2005, conducted from 15 July to 12 August 2005. Supt Nam Liang Chia, Commander of Coastal Command, also joined the team as a facilitator in Australia. The HT C&S course consisted of two modules – one was conducted locally at venues such as IPAM, Police Academy (PA) and New Phoenix Park where the participants were educated on public policies, media engagement and regional security issues. The other module was conducted in Perth, Australia to challenge the participants physically through activities such as abseiling and rafting. The course aims to develop the participants' leadership and management competencies, as well as foster the HT spirit by providing bonding and teamwork opportunities for the participants from the various HT agencies.

**“The opportunity to interact with fellow HT colleagues on a professional as well as personal level was particularly rewarding. The challenging conditions we encountered really built bonds of friendship and camaraderie that I will reminisce about for a long time to come.”**

**DS Damien Gan, Senior Assistant Commander (Ground Operations), Woodlands Command**

**“The course has provided me with a great avenue to seek self discovery and enhance HT bonding, as all participants were constantly exposed to new terrain, new activities and had lots of opportunities to share their thoughts and work together.”**

**DS Lee Teck Seng, Senior Executive, Operations Planning Branch**

**“The course is a journey of experiential learning. Through different activities such as abseiling, trekking, rafting and caving, the course allowed us to learn to lead as well as to work together and motivate one another as a Home Team. The sharing and feedback sessions from mentors, course facilitators and teammates provided us with opportunities to increase our self-awareness and work on our blind spots (what we don't know about ourselves but what others know about us).”**

**DS Chia Hoi Mun, Head of Human Resource Planning & Development Branch**



## CORE COMPETENCY MODULE FOR ICX BASIC COURSE

An account by INSP Victor Tan

The new Core Competency module forms a critical component of our ICX basic course. Insights on Forgery Detection Techniques and Passenger Risk Assessment are included to help ICA perform our core functions at the respective checkpoints.

As part of the Core Competency module, we played host to four foreign senior immigration officers, namely Mr Agus and Mr Agung from Indonesia, and Mr Yit and Ms Suzanne from Hong Kong SAR. They were the first foreign immigration officers invited to join our training since the formation of ICA, marking a milestone in our history books.

Together with our four foreign guests, we practised the examination of various passports. The trainers from IADA and our guests impressed us with their knowledge in passport forgery detection and their commitment to their profession. The class also shared their views freely during the lessons on Passenger Risk Assessment Techniques and Understanding Body Language, heightening our interest in the lessons.

The module provided us with the fundamental and essential knowledge required of new ICA officers. This laid the foundation for us before we embarked on our next phase of training at the checkpoints. The continuous sharing of knowledge definitely helps us to do better.

The foreign officers and our ICX class started the module as immigration counterparts. Two weeks on, we have become fast friends, having shared many memorable moments. One unforgettable experience was our trip to Johor Bahru where our four foreign friends were exposed to a different environment across the causeway.



A hand is shown reaching upwards, with fingers spread, towards a set of blue metal bars. The bars are arranged in a grid-like pattern, with one bar running diagonally from the top left towards the bottom right, and several horizontal bars crossing it. The background is a plain, light blue-grey color. The hand is positioned in the lower right quadrant of the image. There are four black corner brackets around the hand, and four red corner brackets around the text block.

**The facilities in HTA consist of firearms range, sports areas, instructional classrooms, and residential and ceremonial facilities. HTA also has a fully functional training village comprising mock-ups of a checkpoint, a neighbourhood police centre, a prison, a housing board town centre and a school.**

## **THE MOVE TO HOME TEAM ACADEMY (HTA)**

**With inputs from DS Samantha Koh and DS Suzeyani Bte Rashid**

### **READY FOR THE MOVE**

**W**hile others were caught up in the frenzy of New Year preparations, ICA Training Branch was busy preparing for their move from the ICA Academy (or ICAA for short) to the Home Team Academy (HTA) in March 2006.

Located at Old Choa Chu Kang Road, HTA aims to promote HT operational excellence under one roof by leveraging on the unique training capabilities of the respective HT agencies.

### **FACILITIES IN HTA**

A diverse, yet comprehensive provision of facilities and amenities enables the academy to offer a wide range of sophisticated training to all HT officers. The facilities include firearms range, sports areas, instructional classrooms, and residential and ceremonial facilities. HTA also has a fully functional training village comprising mock-ups of a checkpoint, a neighbourhood police centre, a prison, a housing board town centre and a school. When operational, HTA will offer a dynamic scope of courses on counter terrorism, law enforcement, emergency preparedness, leadership and character development.

### **FAREWELL, ICA ACADEMY!**

As HTA gears up to receive ICAA, the Police Academy (also known as TRACOM) and the Prisons Staff Training School in early 2006, it is with mixed feelings that we bid farewell. Since it started its operations in February 2004, ICAA has provided a conducive learning and sharing environment for our officers. We will certainly treasure the wonderful times we have spent at ICAA.

## VISITS BY FOREIGN COUNTERPARTS

The global security situation cannot be tackled by any one country – every country, including Singapore, has a part to play in the fight against terrorism. ICA has collaborated and worked closely with our strategic partners and counterparts on this. We have played host to many of our strategic partners. Here are some of them:



**4 JULY 2005**

Visit by His Highness  
Sheik Tamin Bin Hamad  
Bin Khalifa Al-Thani,  
Heir Apparent State  
of Qatar



**29 AUGUST 2005**

Visit by His Excellency  
Shaik Ahmed Bin  
Mohd Al Khalifa,  
Minister of Finance,  
Kingdom of Bahrain



Get to Know  
Our Seminars  
& Visits



**1 OCTOBER 2005**  
Visit by  
Datuk Haji Abdul Aziz  
Bin Mohd Yusof, Sec-Gen  
(Ministry of Internal Security),  
Malaysia

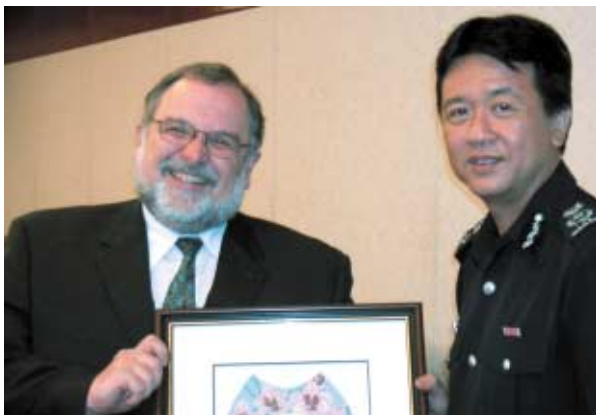

**6 OCTOBER 2005**  
Visit by  
Mr Gary McDonald,  
Director General,  
Policy & Planning,  
Passport Canada, Canada





Chapter

# 5

Get to Know  
Our Achievements  
& Awards



## Get to Know Our Achievements & Awards



### **INNOVATION & CREATIVITY – A+!**

ICA has scored a distinction in the area of creativity – the improvements made in our work processes have won us the coveted Singapore Innovation Class (I-Class) award.

The I-Class award recognises organisations that achieve innovation excellence by adopting a total approach in developing the conditions, culture, competencies and connectivity for sustaining innovation.

ICA has always been well-placed in these areas, constantly producing innovative ideas and inculcating the creative culture in our staff. All the hard work was not in vain when we eventually clinched the award after the assessment on 27 September 2005.

There is no doubt that in this knowledge-based economy, innovation is the hallmark of successful organisations. With the I-Class award on hand, ICA will push for the flourishing of even more creative ideas!

### **HOW MAY I BE OF SERVICE?**

Preparations for the Service Class (S-Class) certification started in late 2004. The first stepping stone towards achieving the certification was the completion of the S-Class report.

ICA officers were engaged through a series of campaigns and briefings so that S-Class and service excellence could be communicated clearly to officers of all levels. A four-part video “Moving Towards Service Excellence” was also released. During the assessment on 28 October 2005, an exhibition was set up outside the ICA HQ Auditorium for the assessors.

ICA had embarked on the pursuit for service excellence long before the S-Class bid. We are constantly improving our services to enhance the quality of our relationship with our customers. Achieving the S-Class certification is a testimony to ICA’s service excellence.



## **POLICE INTELLIGENCE DEPARTMENT (PID) DIRECTOR'S AWARD**

### **With Inputs from AS Ong Kim Boon, Team Leader, Woodlands Command**

#### **PROVIDING AN IMPORTANT LEAD**



S Ong Kim Boon was on duty on 16 October 2004 when he was called on for assistance in a case at Changi Airport Terminal 1, Arrival West.

A female PRC national had been referred to the Team Leader because of some irregularities in her passport. While conducting secondary checks on the PRC national, a male PRC national who had already cleared immigration challenged the ICA officers for checking the lady, despite claiming that he did not know her.

AS Ong Kim Boon became suspicious of the male PRC national and decided to conduct some checks on his baggage. The checks revealed large amounts of black pills and numerous copies of the image of the renowned Chinese physician, named "Hua Tuo" among his belongings. The male PRC national also had name cards bearing another person's name, which he claimed he was carrying for his friend in Singapore. The name cards also showed that "his friend" had a Masters in Chinese medicine. The male PRC national was subsequently referred to the Health Science Authority for carrying large amounts of medicinal products without applying for a permit.

#### **PUTTING TWO AND TWO TOGETHER**

About a fortnight later, AS Ong read a report on cheats from PRC who lingered around HDB estates and approached gullible housewives to promote and sell some black pills at exorbitant prices. By the time the victims realised that they had been cheated, the culprits could no longer be located. The familiar images of "Hua Tuo" featured in the papers led AS Ong to report the case that he had encountered at the airport.

#### **MYSTERY SOLVED!**

After providing the information to the police, the cheat was caught the very next day. Found together with him were two other male and female PRC nationals who were all subsequently charged for cheating. The information given by AS Ong had led to the solving of the case.

AS Ong was subsequently presented with the Police Intelligence Department (PID) Director's Award for excellent intelligence gathering abilities, teamwork and outstanding operational efficiency. He also received ICA Commissioner's Letter of Commendation for his excellent work.



## Get to Know Our Achievements & Awards



### **MHA STAR SERVICE AWARD 2005**

The MHA Star Service Award was first introduced in 2002 by the PS21 Quality Service Committee (QSC) to recognise officers who deliver outstanding public service to both internal and external customers. This award serves to motivate and raise the overall service standards of the public service, showcase role models and encourage and exhort all to follow the shining examples of the award winners.

Three outstanding ICA officers were conferred this prestigious award in 2005. They are DS Lai Nam San (Ports Command), AS Toh Eng Siong (Visitor Services Centre) and CICS John Michael Srithran (Chennai Mission). These officers have exceeded customer expectations by delivering excellent service under difficult conditions. By going out of their way to provide dedicated and extraordinary service to their appreciative customers, our officers deserved this highest accolade within the Home Team.

Our three “Stars” have shown us the importance of serving our customers with dedication and professionalism, and to the best of our ability. Let’s hope there will be more “Stars” arising from ICA in the near future!

#### **STORY OF AS TOH ENG SIONG**

AS Toh Eng Siong has been in service for 16 years and he has an outstanding record of providing consistently high quality services to the public. He participates regularly in quality improvement and service quality activities, and has received many compliments from the appreciative public for his “go the extra mile” attitude and professionalism.

An appreciative Mdm Phua had written in to compliment AS Toh Eng Siong and his colleague, Mrs Lui Kim Geok, for their assistance in expediting the necessary arrangements for her husband to enter Singapore to meet her dying father. Mdm Phua was grateful to our officers for their understanding and efficiency as her husband was able to see his father-in-law for one last time before he passed away. Mdm Phua was also very touched by the sympathy and concern that the officers had shown towards her.

Chapter

# 6

Get to Know  
Our People



## Get to Know Our People



### CHARITY CAR WASH MARATHON

**O**n 24 September 2005, 15 ICA officers took part in the Charity Car Wash Marathon organised by MediaCorp Radio 95.8FM to raise funds for the Asian Women's Welfare Association (AWWA).

The day of the charity car wash dawned bright and sunny. By 10am, the 15 volunteers had reported at the SPC Station at Adams Road to start their mission. The officers were assigned different roles and responsibilities – some were tasked to stand at the entrance of the petrol station to promote the car wash service, while others took on the role of car washers.

As the day progressed, our diligent volunteers managed to attract good business for their station. A total of 72 drivers supported the charity mission and allowed their cars to be washed by the ICA car washers. Our group of volunteers had a pleasant surprise when Ms Zhu Mimi, a famous Hong Kong actress, dropped in to support this event. Our team polished her car to a shine, and of course did not let up the opportunity to pose with her for a group photo.

By 3pm, the tired but satisfied volunteers called it a day and chalked up an impressive \$2,242.30 for a hard day's work.

**“It is a very fulfilling mission to help the needy... we do our share by spending a bit of our time and energy, but the rewards we get in return are so much more satisfying and meaningful.”**

**DS Lua Yik Choon from Permanent Resident Services Centre, ICA volunteer**



## OUR NEW COLLEAGUES



The Annual Team had gotten in touch with a few of our new recruits and talked to them about their learning journeys and aspirations for ICA.

The three officers are:

**INSP Ang Ker Chung** (Woodlands Command) formerly from Singapore Police Force

**INSP Ong Teng Kwee** (Woodlands Command) formerly from Institute of Defence and Strategic Studies (NTU)

**AS Murali Daran Nair** (Tuas Command) formerly from Ministry of Home Affairs as Home Affairs Senior Executive (HASE)

### **❏ What have you learned from your previous working experiences and how do you think you can use your previous knowledge for your work in ICA?**

**Ang:** My service in the SPF, besides instilling a strong sense of discipline and responsibility in me, has taught me to become more independent and proactive in initiating changes and improvements. In ICA, I hope to serve as a model with my committed and enthusiastic work attitude to my colleagues. I also look forward to sharing my past experiences in planning and security to promote experiential learning.

**Ong:** I was previously doing research on terrorism. From my past experiences, I think that law enforcement and security agencies should develop broader and stronger strategic consciousness of events, trends and terrorist activities outside of the country and even beyond the Southeast Asian region, if they wish to avoid strategic and tactical surprises. After joining ICA, I hope to share my knowledge in counter terrorism with my colleagues.

**Murali:** I learned the importance of security for our country and the value of training in developing our officers. Now I look forward to sharing my past experiences in training, operations and intelligence with my colleagues.



**“I learned the importance of security for our country and the value of training in developing our officers. Now I look forward to sharing my past experiences in training, operations and intelligence with my colleagues.”**

**AS Murali Daran Nair (Tuas Command) formerly from Ministry of Home Affairs as Home Affairs Senior Executive (HASE)**

## **2] What are your expectations/hopes for your new job in ICA?**

**Ang:** I hope to rise to new challenges with commitment and dedication, and play a part in contributing towards the success of ICA.

**Ong:** Certainly I hope to learn and gain as much experience as possible and at the same time, make new friends.

**Murali:** In the current climate of terror and crime, I hope to play a role in denying the entry of undesirables into Singapore.

## **3] How have you benefited from the ICX SO basic course?**

**Ang:** The course has equipped me with core skills to be a good team leader as well as an effective team player. It has also enhanced my competency level and boosted my confidence in carrying out my work professionally.

**Ong:** The course familiarises us with ICA's institutional culture and ensures the practice of common standards among new officers by acting as a centralised mode of imparting institutional knowledge. On a lighter note, the course was fun and memorable. OBS, though tough, helped forge lasting friendships and sensitise us to different leadership styles.

**Murali:** The excellent training provided a broad perspective of ICA's core businesses. With the knowledge gained, I look forward to contributing more effectively and efficiently in my work.



## Get to Know Our People

### **Q4] What was the main factor that made you apply for an ICA ICX post?**

**Ang:** ICA faces evolving challenges in the enforcement of immigration legislations and the maintenance of border security. I had decided to embark on an ICA career to take on these new challenges that allow me to continue serving our community and country.

**Ong:** I believe, strongly, that ICA plays a vital role in defending our country against peacetime alien threats. While other law enforcement agencies may appear more prominent in the eyes of the public, ICA should play a proactive frontline role and be recognised for it.

**Murali:** The job scope with a mission to serve our people and protect our country against undesirables is the main reason for me to join ICA.



**“I hope to rise to new challenges with commitment and dedication, and play a part in contributing towards the success of ICA.”**

**INSP Ang Ker Chung (Woodlands Command) formerly from Singapore Police Force**



**“I believe, strongly, that ICA plays a vital role in defending our country against peacetime alien threats. While other law enforcement agencies may appear more prominent in the eyes of the public, ICA should play a proactive frontline role and be recognised for it.”**

**INSP Ong Teng Kwee (Woodlands Command) formerly from Institute of Defence and Strategic Studies (NTU)**

**13 & 14 JANUARY 2005**  
**Corporate Planning Seminar**  
NTUC Centre,  
1 Marina Boulevard



**28 APRIL 2005**  
**Workplan Seminar**  
ITE Dover



**19 JUNE 2005**  
**Family Day**  
Pasir Ris Park





Get to Know  
Our People

**1 OCTOBER 2005**  
**ICA Cross Country**  
**cum Nature Walk**  
MacRitchie Reservoir



**26 NOVEMBER 2005**  
**ICA Dinner & Dance**  
Suntec Ballroom



Get to Know  
Our ICA Annual  
Committee



LEFT TO RIGHT

**MR ROBIN LEE**  
MEMBER

**MS KONG YONG SIN**  
MEMBER

**MS TAN SUSIE**  
CHAIRPERSON



LEFT TO RIGHT

**MR ALEX CHIN**  
MEMBER

**MR CHIA WEI KIANG**  
EDITOR



LEFT TO RIGHT

**MS LAI WEI LIN**  
SECRETARY

**MS MARIE MOK**  
ASSISTANT EDITOR

**MS NG PEI HSIEN**  
MEMBER



Designed & Produced by  
**RAINDANCE**





IMMIGRATION & CHECKPOINTS AUTHORITY

ICA Building  
10 Kallang Road #08-00  
Singapore 208718

[www.ica.gov.sg](http://www.ica.gov.sg)